

Turkey

Theme: Self-similar

Difficult to fold using 6" (15 cm) origami paper. 10" (25 cm) to 12" (30 cm) very thin paper is suggested.

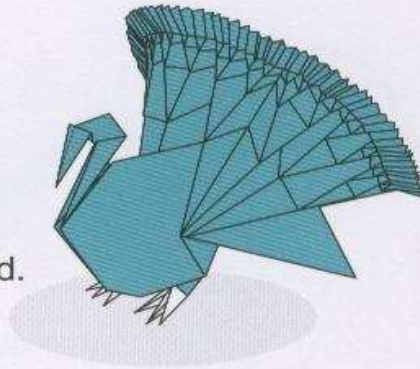

First, you need to decide how fine you would like to make the tail. That defines how many times you have to repeat the steps. Repeat five times for the picture on the left and in the beginning of this book, though the diagram instructs to repeat three times.

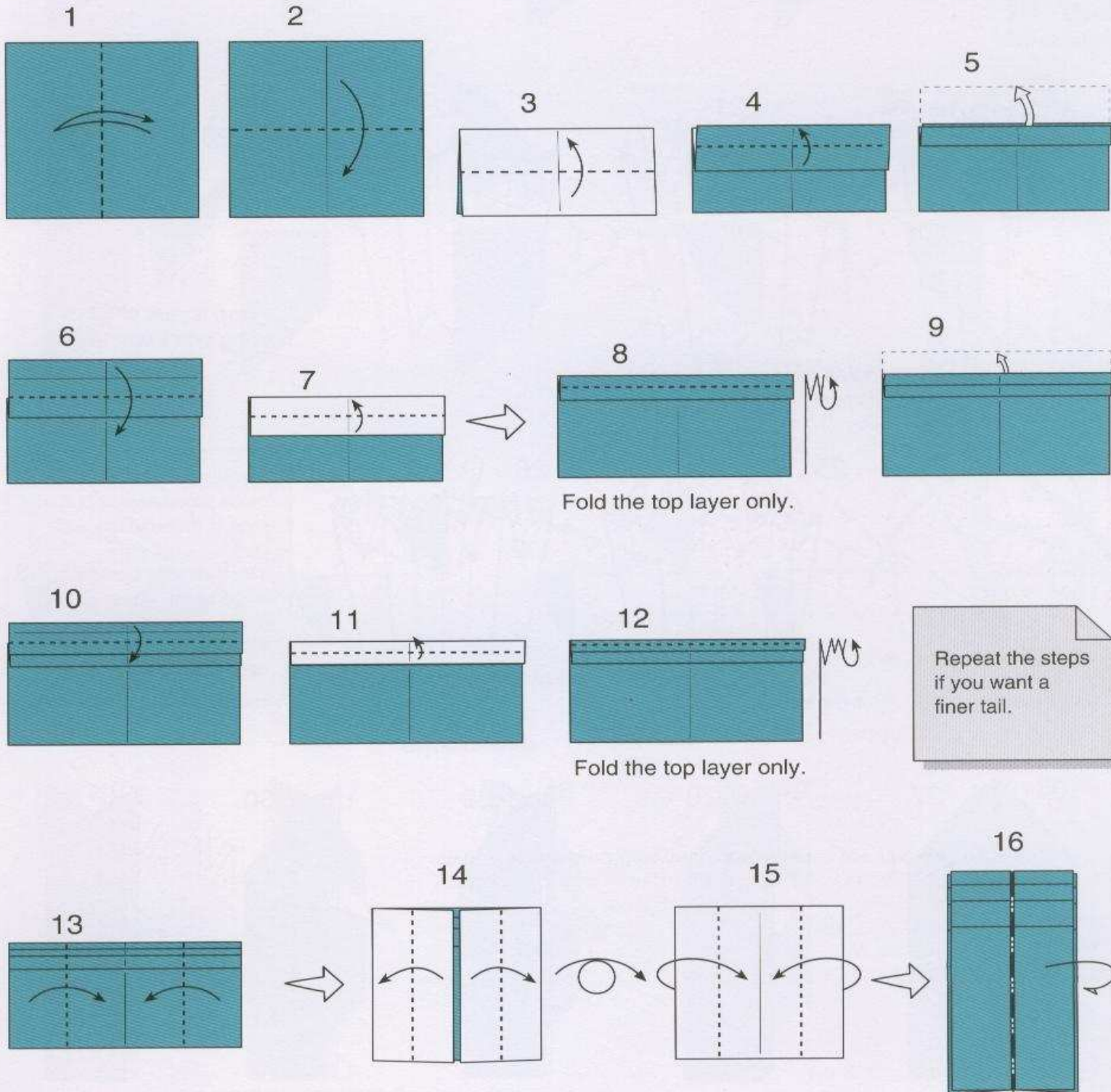

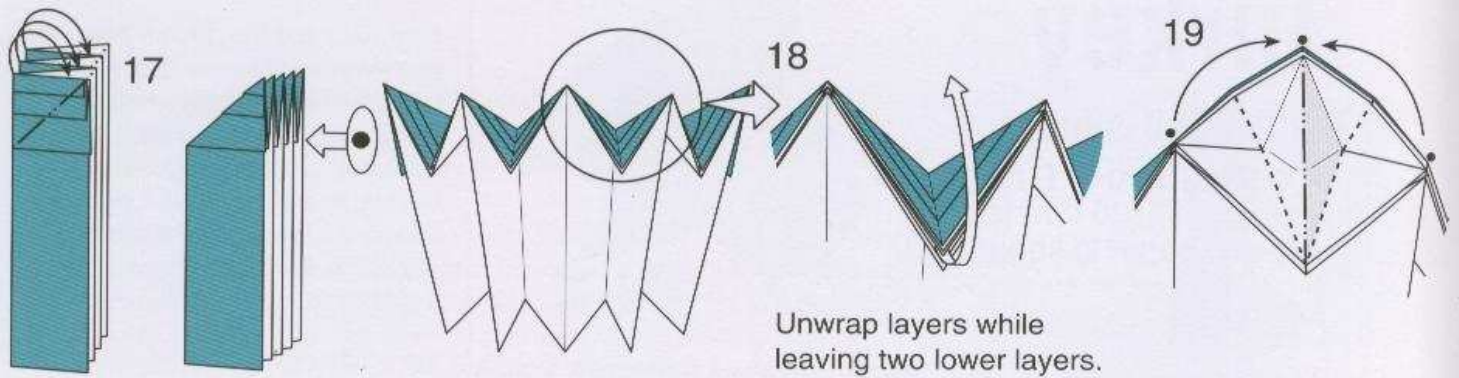

Inside reverse-fold

Unwrap layers while leaving two lower layers.

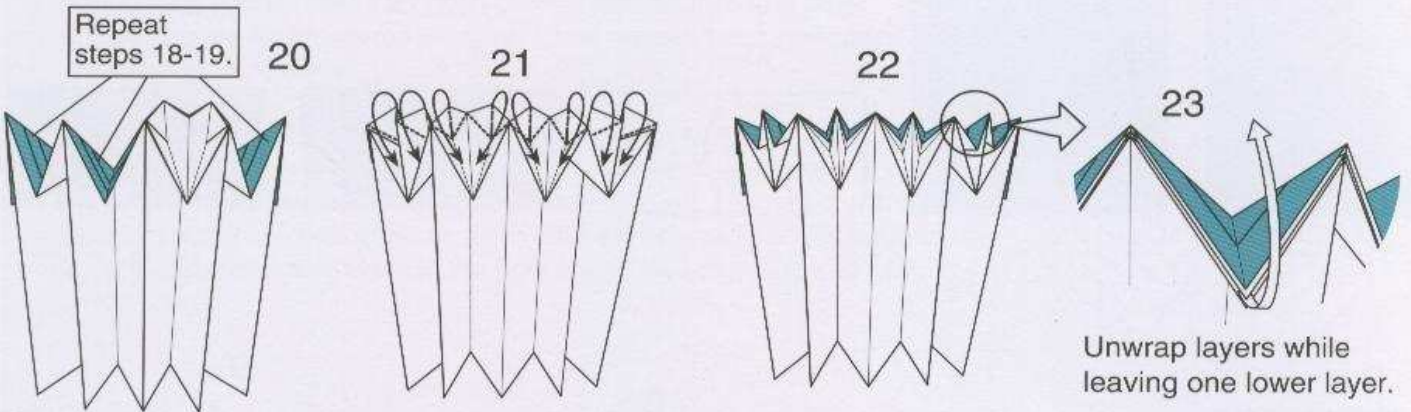

Inside reverse-fold eight times

Unwrap layers while leaving one lower layer.

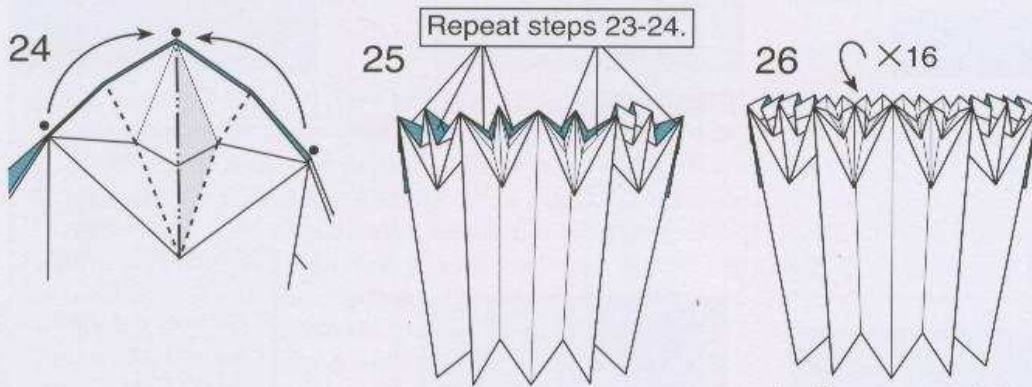

Inside reverse-fold sixteen times

If you have repeated more times at step 13, repeat these steps as well. You can also unwrap the edge of the paper to make rectangles, as in the picture in the beginning of the book.

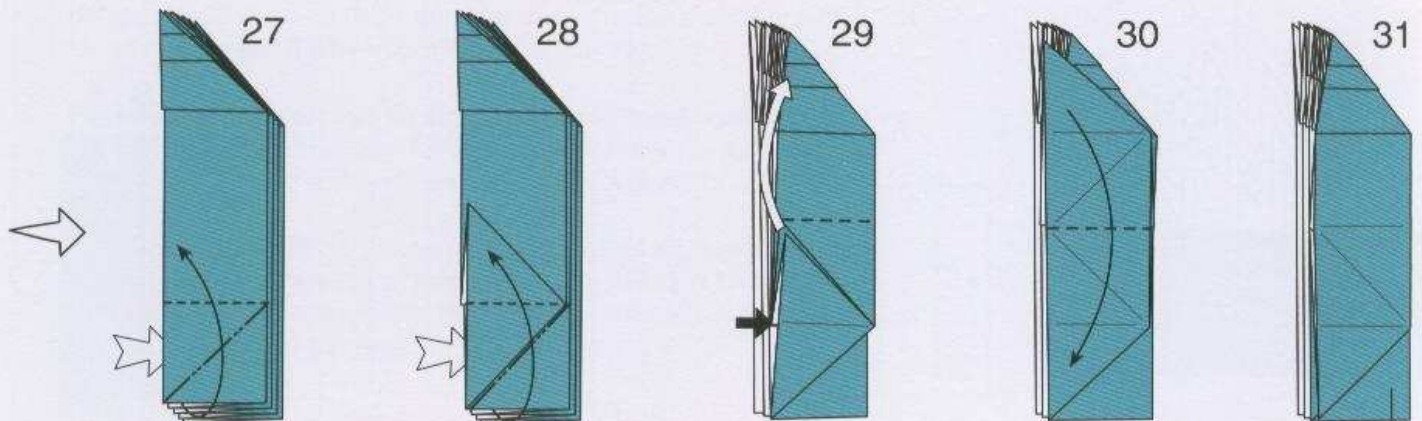

Stretch and squash to make a trapezoid.

Repeat steps 27-30.

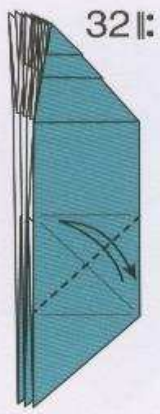

32:



33

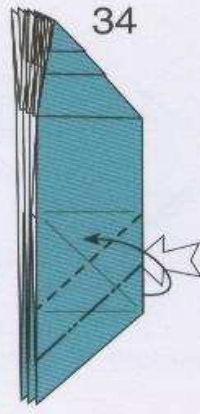

34



35

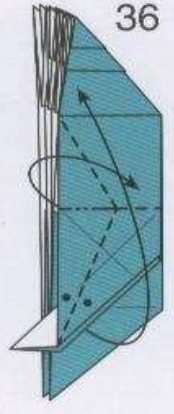

36

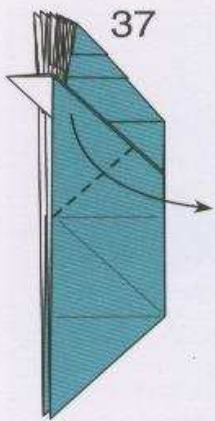

37

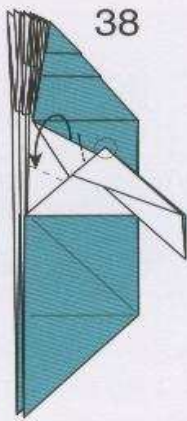

38

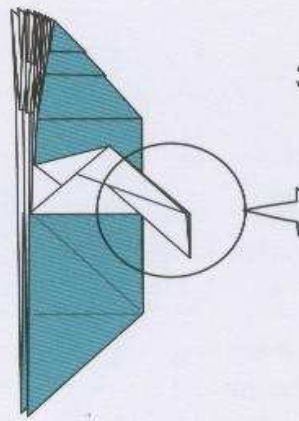

39

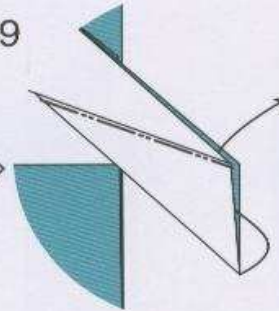

40

Inside reverse-fold

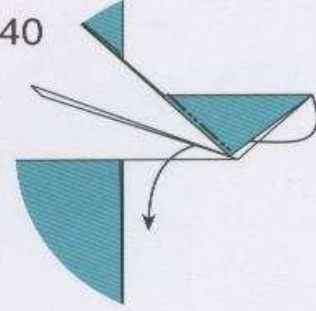

Inside reverse-fold

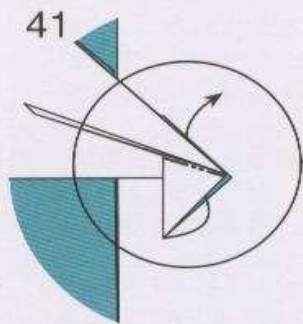

41

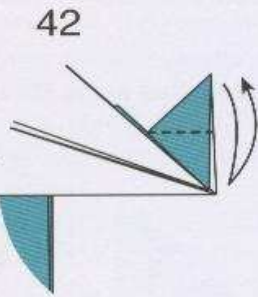

42

Inside reverse-fold

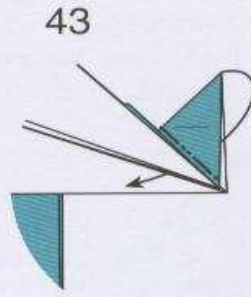

43

Inside reverse-fold



44

Inside reverse-fold

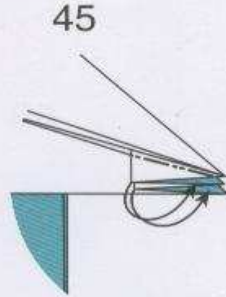

45

Inside reverse-fold

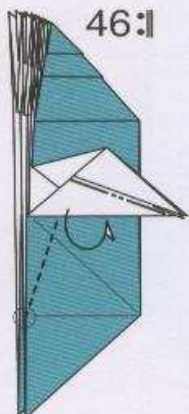

46:

Swivel-fold

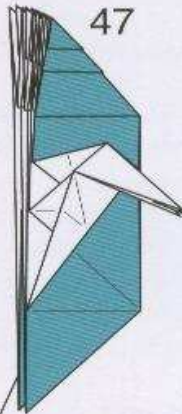

47

Repeat steps 32-46.

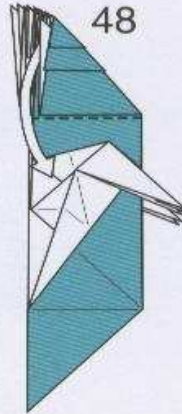

48

Pull out the hidden flap.

Repeat steps 48-49.

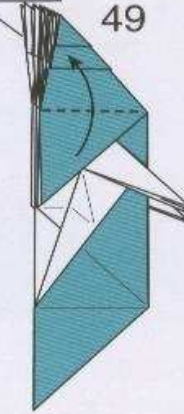

49

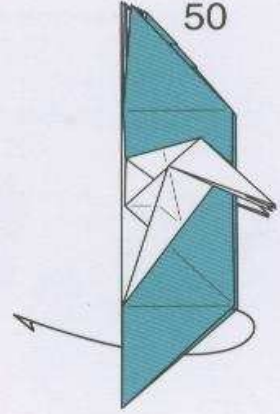

50

51

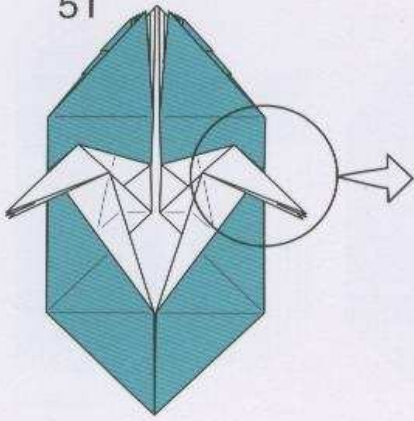

52

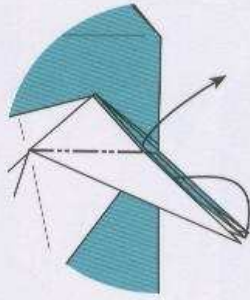

Inside reverse-fold

53

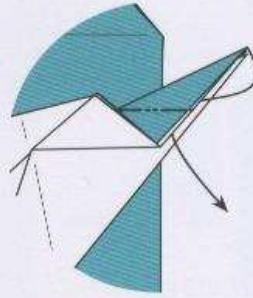

Inside reverse-fold

54

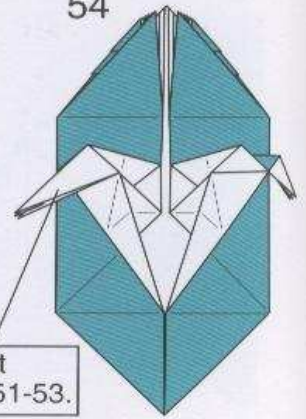

Repeat steps 51-53.

55

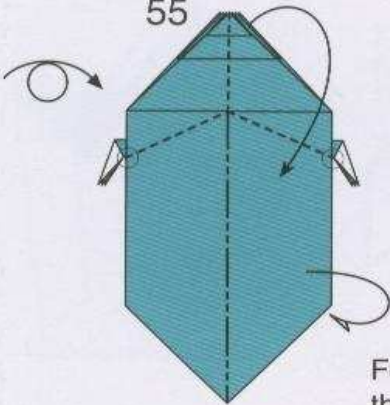

56

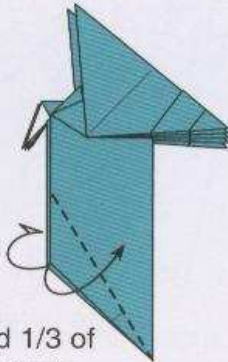

Fold 1/3 of the angle.

57

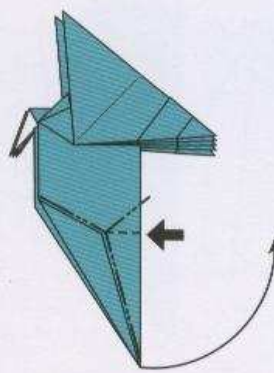

Double rabbit-ear-fold

58

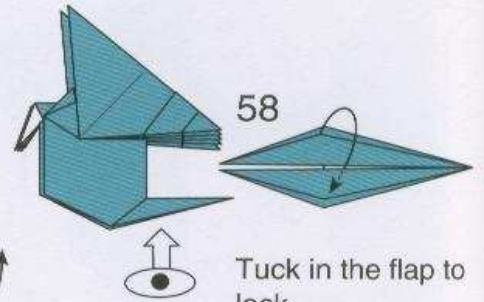

Tuck in the flap to lock.

59

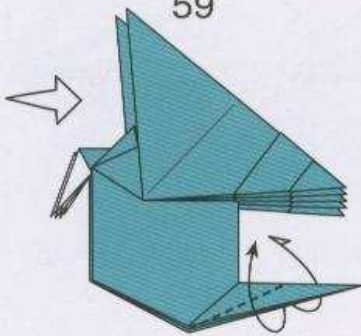

Outside reverse-fold

60

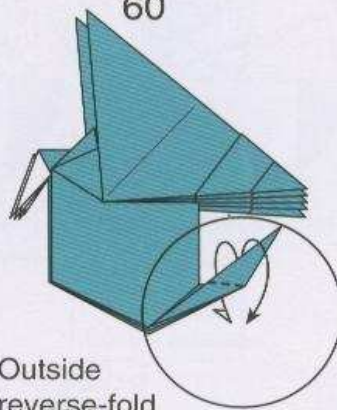

Outside reverse-fold

61

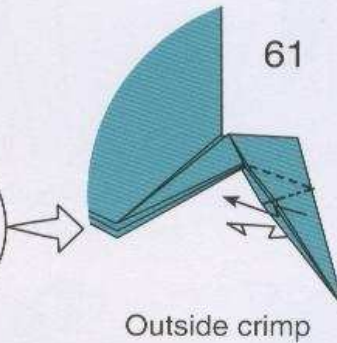

Outside crimp

Fold the point so that it becomes a wattle, not a beak.

Center

62

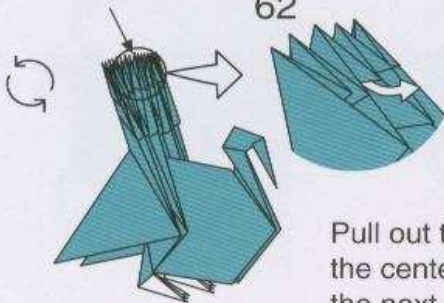

Pull out the small flap at the center and tuck it into the next pocket to lock. (You can omit this step.)

63

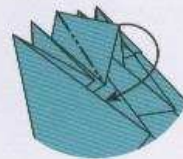

64

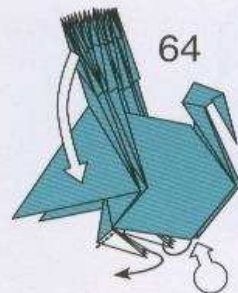

Open the legs and tail and inflate the body slightly.

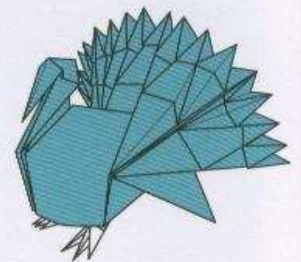

Finished.